



BIDS AND AWARDS COMMITTEE

NOTICE OF NEGOTIATED PROCUREMENT

The Philippine International Convention Center (PICC) announces that the Bids and Awards Committee (BAC) will conduct a Negotiated Procurement for the **SUPPLY OF LABOR AND MATERIALS FOR THE FABRICATION/CONSTRUCTION OF EXTERIOR STEEL STAIRWAYS AT THE POWERHOUSE BUILDING FOR ACCESSING ITS ROOF DECK**. The total Approved Budget for Contract (ABC) for this requirement is **THREE HUNDRED NINETY-FIVE THOUSAND PESOS (P395,000.00), VAT inclusive**.

This will be undertaken in accordance with Sec. 53.1, Two Failed Bids, of the Revised Implementing Rules and Regulations (RIRR) of Republic Act No. 9184 otherwise known as "The Government Procurement Reform Act".

A complete set of documents may be obtained by interested bidders from April 12, 2019 to on or before 5:00 p.m. of April 23, 2019 and upon payment in cash of a non-refundable fee of **FIVE HUNDRED PESOS (P900.00)**.

Submission of proposals will be on or before 5:00 p.m. of April 23, 2019, at the BAC Secretariat Office, Ground Floor, Delegation Building, PICC Complex, 1307 Pasay City. Attached are the specifications for this particular procurement.

MELPIN A. GONZAGA
Chairman

BIDS AND AWARDS COMMITTEE (BAC)

NEGOTIATED PROCUREMENT

Sir:

We wish to inform you that the procurement of the **SUPPLY OF LABOR AND MATERIALS FOR THE FABRICATION/CONSTRUCTION OF EXTERIOR STEEL**, will be done by way of Alternative Method of Procurement through Negotiated Procurement.

The total Approved Budget for Contract (ABC) for this project is **THREE HUNDRED NINETY-FIVE THOUSAND PESOS (P395,000.00), VAT inclusive.**

Please submit your proposal on or before **5:00 p.m. of April 23, 2019** at the BAC Secretariat, Ground floor, Delegation Building, PICC together with the following:

A. ELIGIBILITY DOCUMENTS:

1. Certified photocopy of the valid and current PhilGEPS Certificate of Registration – Platinum Membership. If any of the documents mentioned in Annex "A" is not current, the new document should be submitted.

If any of the documents mentioned in Annex "A" is not current, the new document should be submitted.

2. Statement of all on-going government and private contracts, including contracts awarded but not yet started, if any, whether similar or not similar in nature and complexity to the contract to be bid;
3. Statement of the Single Largest Completed Contract (SLCC) similar to the contract to be bid, entered into within the last three (3) years from the date of submission and opening of bids, and whose value is at least fifty percent (50%) of the ABC. Attach to such statement the following;

- a. Certified photocopy of the SLCC; and
- b. Certificate of Acceptance or Official Receipt or Sales Invoice

4. Net Financial Contracting Capacity (NFCC):

Computation of NFCC must be at least equal to the ABC to be bid, calculated as follows;

NFCC = [(Current assets minus current liabilities) (15)] minus the value of all outstanding or uncompleted portions of the projects under ongoing contracts, including awarded contracts yet to be started, coinciding with the contract to be bid.

or a committed Line of Credit from Universal or Commercial Bank, in lieu of its NFCC Computation. The committed Line of Credit must be at least equal to ten percent (10%) of the ABC to be bid.

B. TECHNICAL COMPONENT:

1. Terms of Reference fully accomplished;
2. Notarized Omnibus Sworn Statement with attached;
 - a. For Corporations, the duly notarized Secretary's Certificate; or
 - b. For Sole Proprietorship, the notarized Special Power of Attorney.

C. OTHER DOCUMENTARY REQUIREMENTS:

1. Certified photocopy of the CY 2017 Income and Business Tax Returns filed and paid through the BIR Electronic Filing and Payment System (eFPS);
2. Company Profile with Organizational Chart and sketch of office location;
3. Certification from PICC' Mechanical Services Division that the participating bidder has conducted ocular inspection of the subject requirement; and
4. Certificate of Satisfactory Completion & Acceptance of previous PICC projects undertaken within the last three (3) years, if any.

Negotiation shall be made with the bidder who made the lowest offer; should the negotiation fail then the same shall be made with the second lowest offer.

Attached is the Terms of Reference and other requirements for the implementation of the abovementioned requirements.

PICC reserves the right to reject any offer or all quotations found to be disadvantageous to the government.

Very truly yours,

MELPIN A. GONZAGA
Chairman 

Date

The Chairman
Bids and Awards Committee (BAC)
Philippine International Convention Center (PICC)

Dear Sir/Madam:

In response to your letter dated _____, 2019, I wish to submit our offer for the **SUPPLY OF LABOR AND MATERIALS FOR THE FABRICATION /CONSTRUCTION OF EXTERIOR STEEL.**

TOTAL ANNUAL CONTRACT RATE: INCLUSIVE OF VALUE ADDED TAX (VAT)

(Amount in Words) (P _____)
(Amount in figures)

Very truly yours,

Signature of bidder over printed name

Address

Telephone/Fax No.

TERMS OF REFERENCE

A. TECHNICAL SPECIFICATIONS

Item No.	Article /Description	COMPLIANCE
1	<p>SUPPLY OF LABOR AND MATERIALS FOR THE FABRICATION/CONSTRUCTION OF EXTERIOR STEEL STAIRWAYS AT THE POWERHOUSE BUILDING FOR ACCESSING ITS ROOF DECK</p> <p>A. SPECIFIC WORKS</p> <p>Supply of labor, materials, tools, technical expertise, supervision and safety watch for the fabrication/construction of exterior steel stairways at the Powerhouse Building for accessing its Roof Deck. The scope of work includes but not necessarily limited to the following:</p> <ol style="list-style-type: none"> 1. Mobilization of equipment. 2. Install/assemble scaffolding/s at the job site to facilitate safe and faster completion of the proposed project. 3. Fabricate and install/construct support posts for the stairway landings and steel framing. Support pipes/base plates must be bolted to a cemented footing and with the following materials specifications: <ol style="list-style-type: none"> 3.1 Posts - Use B.I. Pipes, 3" O.D., Schedule 40 3.2 Handrails/Supports - Use B.I. Pipes, 2" O.D. Schedule 40 & 12mm square bar 3.3 Framings/Steps - Use Angle Bar, 2" x 2" x 1/4" T 3.4 Landings - Use Checkered Plate, 2mm thickness 4. Install/provide handrails and needed supports to fortify attachments to main frame. 5. Install/provide checkered steel plate coverings at each steps and landings. 6. Replace the existing rusted catwalks with checkered steel plate and provide additional framings and supports to secure a more safe walkway leading to the new exterior steel stairways. 7. Paint the finished and already approved stairways with a coat of epoxy primer and at least 2 coats of epoxy gray finish. 8. Project turnover <p>B. CONDITIONS</p> <ol style="list-style-type: none"> 1. The Contractor must conduct site survey and inspection. 2. The Contractor shall provide a sufficient number of safety personnel for the duration of the work. Safety personnel shall monitor the Contractor's personnel as they carry out the work and be responsible for hazard assessment, first aid, safety watch, spotter duties, gas monitoring, hot works monitoring etc. 	

16

3. All painting materials will be stored at a designated place at the cooling tower area. Wastes generated and paint containers should be segregated and stored temporarily at a designated area at the site during the duration of work. Said wastes shall be brought-out of PICC premises after project completion and acceptance. Disposal shall be of the Contractor's responsibility.
4. Any work that may affect the operation and security measures of PICC shall be coordinated properly and shall be done in accordance with the PICC' approved schedule.
5. The contractor shall report to PICC on or before the bidding, any perceived or evident condition that would prevent him from performing first class work.
6. Thickness of the above-mentioned materials to be used in the actual fabrication could be thicker than the required but it must not be thinner.
7. The metal frame sections that would be covered with the checkered plates must be painted first with epoxy primer and epoxy paint finishes in gray color and in two (2) coats before the installation of the said metal sheet. Total or complete painting could be done after the completion/approval of the finished stairways.
8. "Hot works" can only be done in a designated area and that, a personal fire extinguisher/s should always be stationed in the area for emergency purpose.
9. Power supply for welding works shall be provided by the PICC.
10. The Contractor must submit NBI/Police Clearance of its personnel to be assigned at the PICC.
11. Contractor's personnel must be in their company uniform and ID while inside the PICC premises.
12. The Contractor should free the PICC and its personnel from and against all liabilities arising from injuries or liabilities to persons or damages to property occasioned by any act or omissions by the Contractor including any and all expenses, legal or otherwise which may be incurred by PICC and its personnel in the defense of any claim, action or suit.

Statement of Compliance

Offerors must state here either "Comply" or "Not Comply" against each of the individual parameters of each Specification stating the corresponding performance parameter of the equipment offered.

B. Performance Bond

Form of Performance Security	Amount of Performance Security (Equal to Percentage of the Total Contract Price)
Cash or Cashier's/Manager's Check issued by a Universal or Commercial Bank.	Five percent (5%)
Bank draft/guarantee issued by a Universal or Commercial Bank	Five percent (5%)
Surety bond callable upon demand issued by a surety or insurance company duly certified by the Insurance Commission as authorized to issue such security.	Thirty percent (30%)

C. PAYMENT

Full payment shall be released in full within three (3) weeks after final acceptance by PICC or its representative of the Contractor's completed work, and submission of billing and complete supporting documents by Contractor as follows:

- 1) Service Report/Accomplishment Report
- 2) Invoice
- 3) Copy of delivery receipt for the return of replaced parts/materials, if any.

Payment is subject to retention of five percent (5%) referred to as the "retention money". The said amount shall be released after the lapse of the warranty period.

D. Schedule of Requirements

Item No.	Description	Contract Period
1	Supply of Labor and Materials for the Fabrication/Construction of exterior steel stairways at the Powerhouse Building for Accessing its roof decks	Work shall be completed within twenty-five (25) calendar days from the receipt of the Notice to Proceed.

I hereby commit to comply and deliver all the above requirements in accordance with the above stated schedule.

Name of Company / Bidder

Signature over printed Name of Authorized Representative

Position



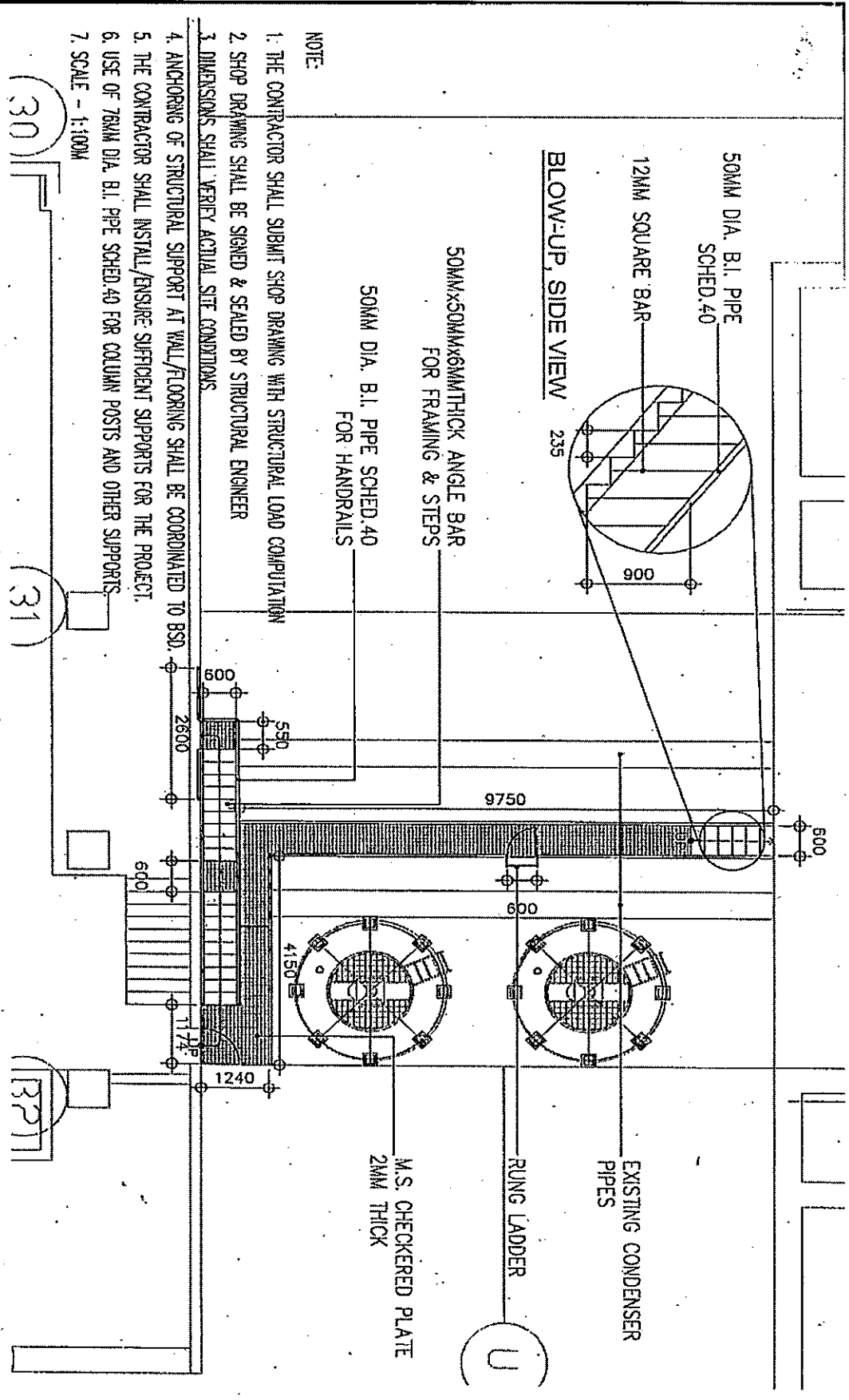



Date

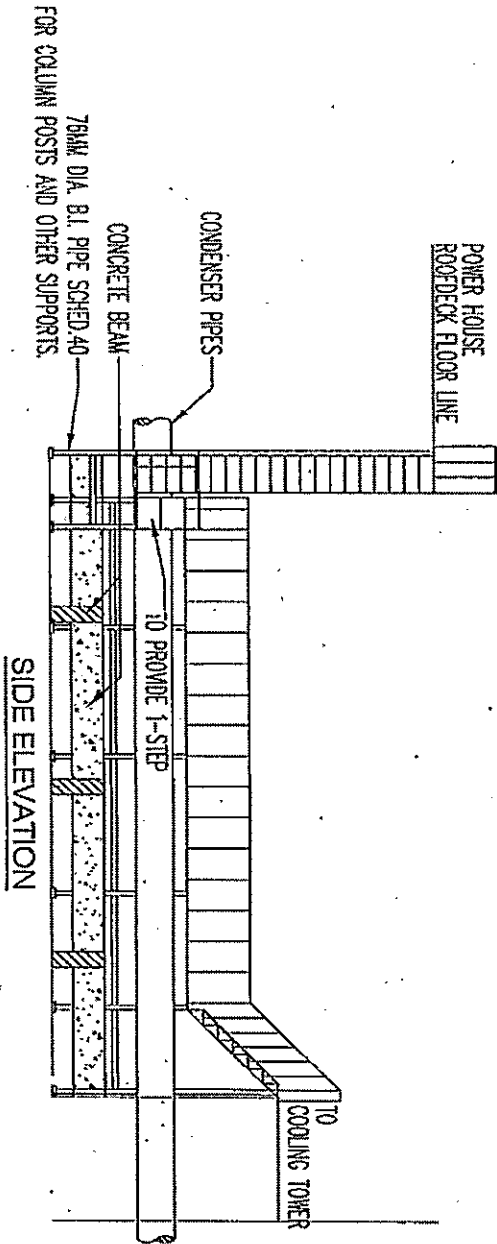
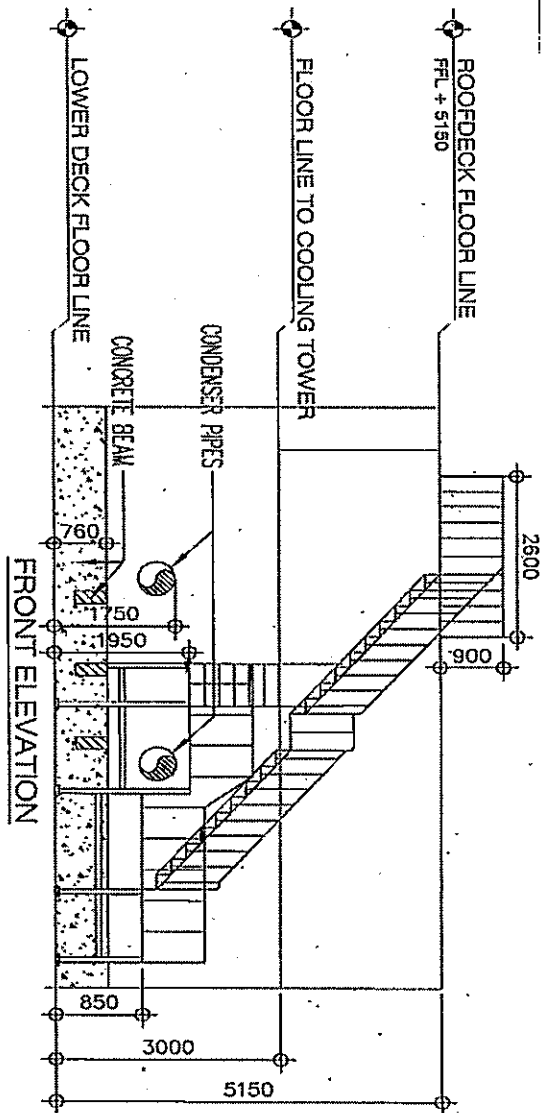

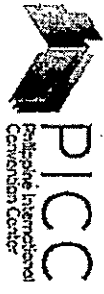
- NOTE:
1. THE CONTRACTOR SHALL SUBMIT SHOP DRAWING WITH STRUCTURAL LOAD COMPUTATION
 2. SHOP DRAWING SHALL BE SIGNED & SEALED BY STRUCTURAL ENGINEER
 3. DIMENSIONS SHALL VERIFY ACTUAL SITE CONDITIONS
 4. ANCHORING OF STRUCTURAL SUPPORT AT WALL/FLOORING SHALL BE COORDINATED TO BSD.
 5. THE CONTRACTOR SHALL INSTALL/ENSURE SUFFICIENT SUPPORTS FOR THE PROJECT.
 6. USE OF 76MM DIA. B.I. PIPE SCHED. 40 FOR COLUMN POSTS AND OTHER SUPPORTS
 7. SCALE - 1:100M

	TITLE	DATE	DRAWN BY	RECOMMENDING FOR APPROVAL	APPROVED BY
	PROPOSED EXTERIOR STEEL STAIRWAYS AT THE POWERHOUSE BUILDING LOCATION PICC COMPLEX, PASAY CITY	08-08-18	ENGR. MARCO B. MACANAN ASSISTANT DIRECTOR MSD	ENGR. WILSON B. DELOS REYES DIRECTOR, MSD	ENGR. RICHARD T. ULLIBAO SENIOR CONSULTING TECH. MSD ENGR. MARCO B. MACANAN ASSISTANT DIRECTOR MSD
	REVISION	CHECKED BY			
	00	ENGR. MARCO B. MACANAN			

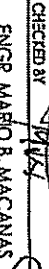

		TITLE PROPOSED EXTERIOR STEEL STAIRWAYS AT THE POWERHOUSE BUILDING		DATE 09-26-18	DRAWN BY  ENGR. EDWIN A. JUBILADO SENIOR ENGINEER, MSD	RECOMMENDING FOR APPROVAL  ENGR. WILSON B. DEOS REYES DIRECTOR, MSD	APPROVED BY  ENGR. MARIO B. MACANAS ASSISTANT DIRECTOR, MSD
LOCATION PICCC COMPLEX, PASAY CITY		REVISION 00	CHECKED BY  ENGR. MARIO B. MACANAS ASSISTANT DIRECTOR, MSD	RECOMMENDING FOR APPROVAL  ENGR. WILSON B. DEOS REYES DIRECTOR, MSD		APPROVED BY  ENGR. MARIO B. MACANAS ASSISTANT DIRECTOR, MSD	



PICCC
Philippine International
Convention Center

ISOMETRIC DRAWING

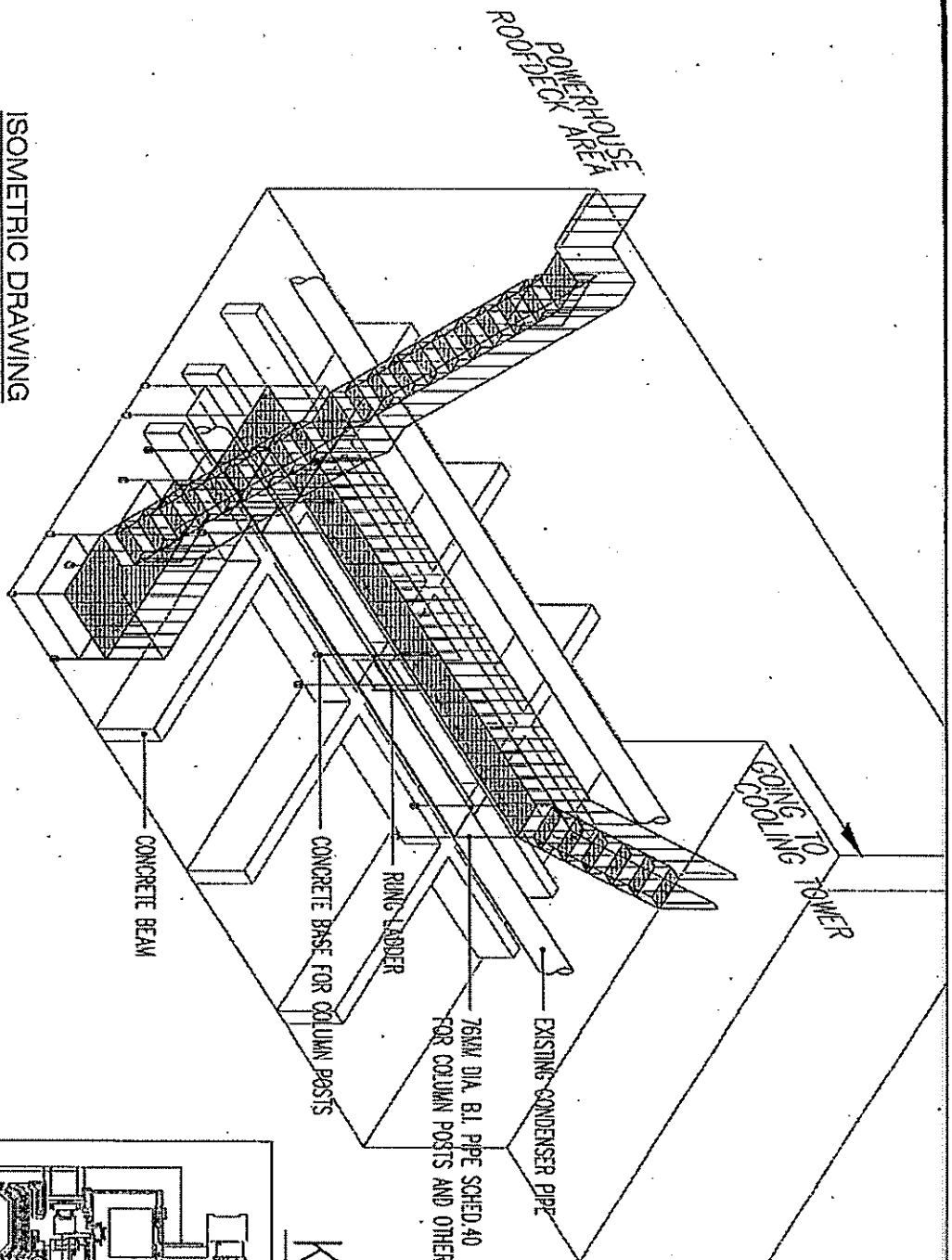

KEY PLAN

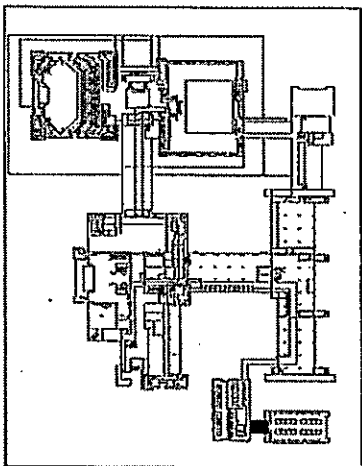

TITLE		DATE	DRAWN BY	RECOMMENDING FOR APPROVAL	APPROVED BY
PROPOSED EXTERIOR STEEL STAIRWAYS AT THE POWERHOUSE BUILDING		08-08-18	ENGR. MARIO B. MACANASY ASSISTANT DIRECTOR, ASD	ENGR. WILSON B. DELLOS REYES DIRECTOR, ISD	ENGR. RICHARD B. CAVILLA GENERAL MANAGER
LOCATION		REVISION	CHECKED BY		
PICCC COMPLEX, PASAY CITY		00	ENGR. MARIO B. MACANASY ASSISTANT DIRECTOR, ASD		

Go to Settings to activate Windows

NOTE:

1. THE CONTRACTOR SHALL SUBMIT SHOP DRAWING WITH STRUCTURAL LOAD COMPUTATION
2. SHOP DRAWING SHALL BE SIGNED & SEALED BY STRUCTURAL ENGINEER
3. DIMENSIONS SHALL VERIFY ACTUAL SITE CONDITIONS.
4. ANCHORING OF STRUCTURAL SUPPORT AT WALL/FLOORING SHALL BE COORDINATED TO BSD.
5. THE CONTRACTOR SHALL INSTALL/ENSURE SUFFICIENT SUPPORTS FOR THE PROJECT.
6. USE OF 76MM DIA. B.I. PIPE SCHED.40 FOR COLUMN POSTS AND OTHER SUPPORTS.
7. SCALE - 1:100M

50MMx50MMx6MM THICK ANGLE BAR
FOR FRAMING & STEPS
50MM DIA. B.I. PIPE SCHED.40
FOR HANDRAILS

KEY PLAN

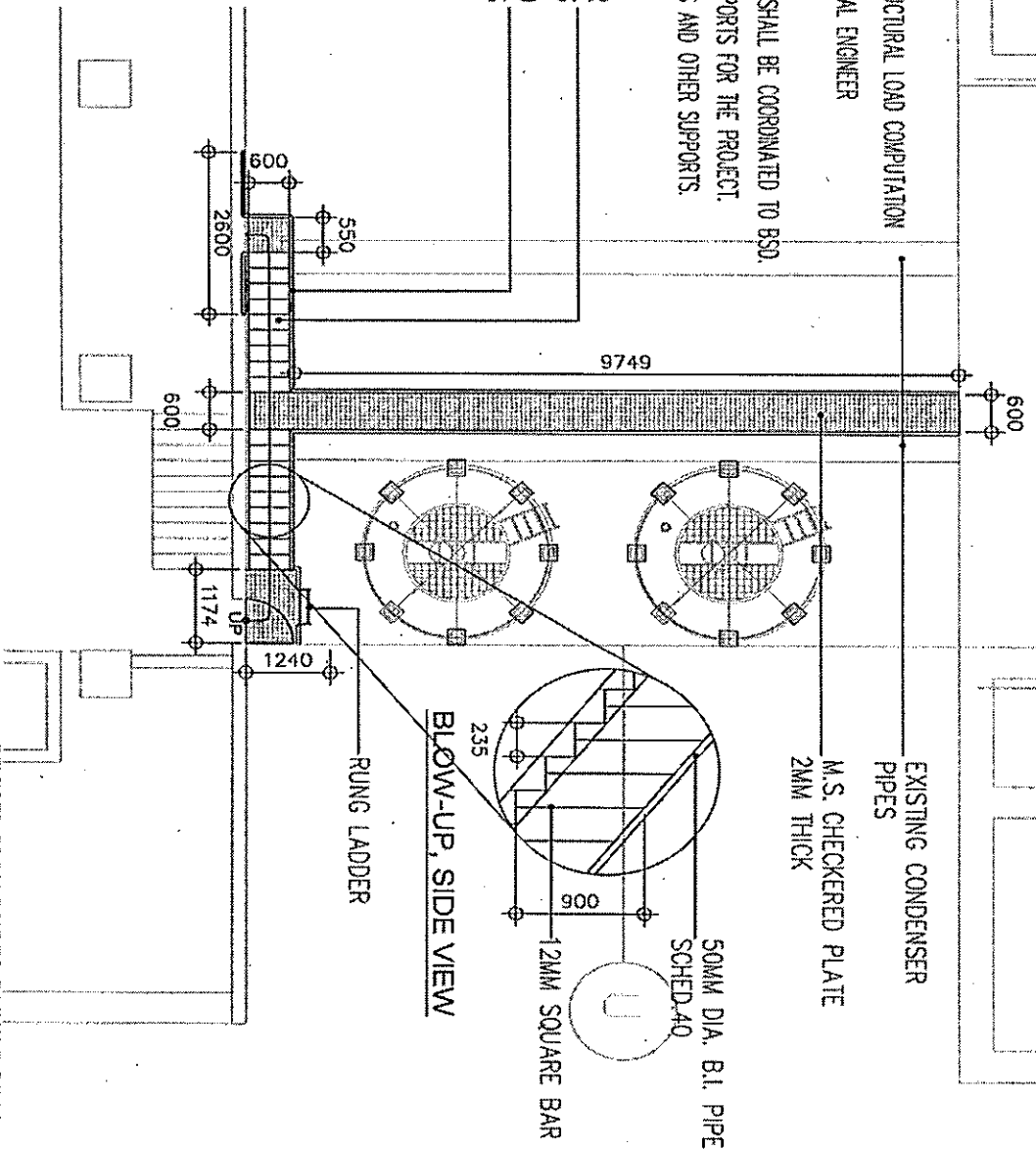
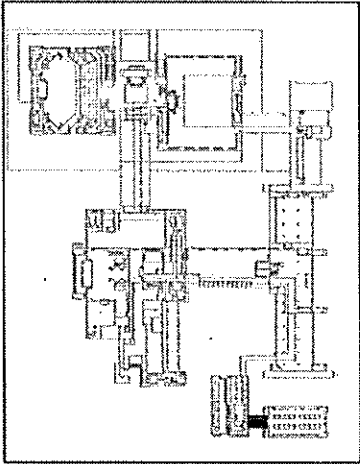



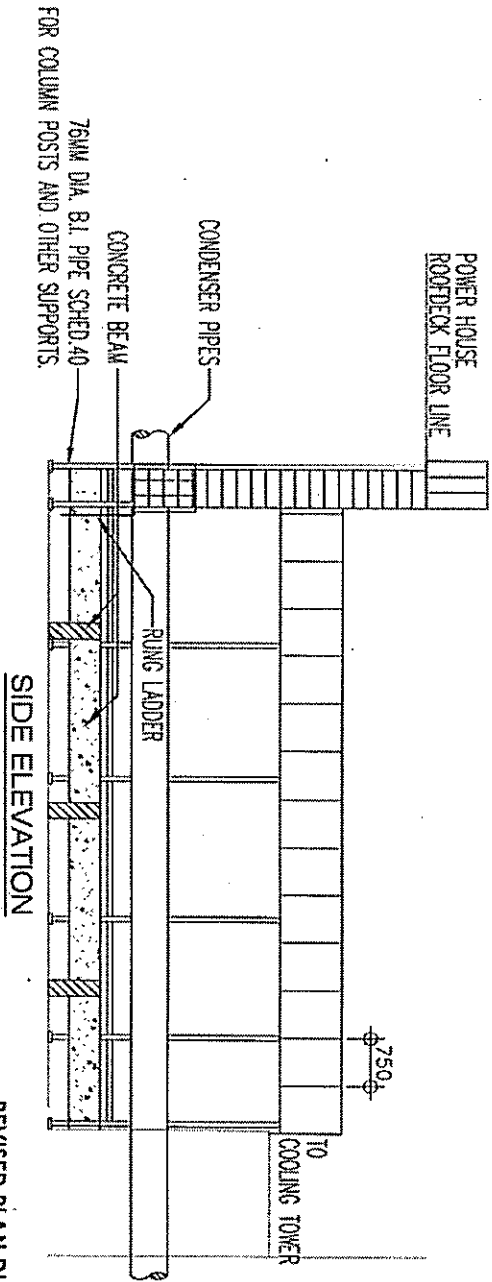
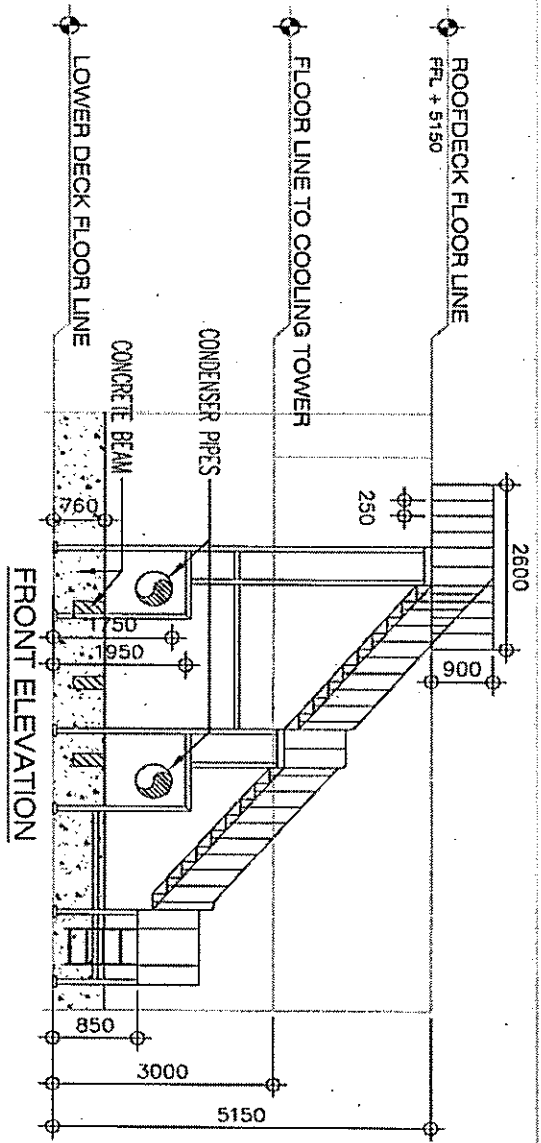

REVISED PLAN DUE TO FAILURE OF BID

 <p>PICC Philippine International Construction Center</p>		<p>TITLE PROPOSED EXTERIOR STEEL STAIRWAYS AT THE POWERHOUSE BUILDING</p>		<p>DATE 08-08-18</p>		<p>DRAWN BY ENGR. ROY B. JUBILADO SR. STRUCTURAL ENGINEER, ASD</p>		<p>RECOMMENDING FOR APPROVAL</p>		<p>APPROVED BY</p>	
<p>LOCATION PICC COMPLEX, PASAY CITY</p>		<p>REVISION 01</p>		<p>CHECKED BY ENGR. MARIO B. MACANAS ASSISTANT DIRECTOR, ASD</p>		<p>ENGR. WILSON B. DELOS REYES DIRECTOR, ISD</p>		<p>ATTY. R. RODRIGUEZ ATTY. R. RODRIGUEZ</p>		<p>ATTY. R. RODRIGUEZ ATTY. R. RODRIGUEZ</p>	



REVISED PLAN DUE TO FAILURE OF BID

	TITLE	DATE	DRAWN BY	RECOMMENDING FOR APPROVAL	APPROVED BY
	PROPOSED EXTERIOR STEEL STAIRWAYS AT THE POWERHOUSE BUILDING	09-26-18	 ENGR. MARIO B. MACANAVA ASSISTANT DIRECTOR, ASD	 ENGR. WILSON B. DEOS REYES DIRECTOR, ISD	 ENGR. RENATO B. PADILLA GENERAL MANAGER
LOCATION	REVISION	CHECKED BY	Go to Settings to activate Windows		
PICCC COMPLEX, PASAY CITY	01	 ENGR. MARIO B. MACANAVA ASSISTANT DIRECTOR, ASD			

2