

SUPPLEMENTAL BID BULLETIN

**Republic of the Philippines
PHILIPPINE INTERNATIONAL CONVENTION CENTER
PICC Complex, 1307 Pasay City
BIDS AND AWARDS COMMITTEE (BAC)**

April 18, 2024

**SUPPLY OF LABOR AND MATERIALS FOR THE REHABILITATION OF THE
ROOF OF MEETING ROOM I**

ADDENDUM NO. 01

This Addendum is issued to amend/revise certain provisions of the Bid Documents for the above-captioned procurement. Said amendments are as follows:

I. Section III- Bid Data Sheet have been revised to read as:

- ITB Clause 10.4- Key Personnel
 - The key personnel must meet the required minimum years of experience set below:

Key Personnel	Relevant Experience
1 – Fulltime Project-in-Charge	Must have at least five (5) years' experience as Supervisor and/or Installer in PVC membrane waterproofing works. Must have a Certificate of employment as Supervisor in the installation of the PVC waterproofing system and with Certificate of training as Installer of PVC waterproofing membrane from the manufacturer.
3– PVC Membrane Installers	Minimum of three (3) years' work experience as installer of PVC membrane. Must have Certification of employment as Installer of PVC Membrane waterproofing and Certificate of training as Installer of PVC waterproofing membrane from the Manufacturer
1 – Safety Officer	Minimum of three (3) years' work experience as Safety Officer/Practitioner. Must have Certificate of employment as Safety Officer and Certificate of training in Occupational Safety and Health from DOLE or any DOLE accredited training institution.

- ITB Clause 10.5 -The minimum major equipment required to the project:

Item No.	Number of Units	Description of Equipment
1.	1 – unit	Automatic Welding Machine for PVC Membrane
2.	3 – units	Hand Welding Guns for PVC Membrane

- ITB Clause 20.2

- Within a non-extendible period of five (5) calendar days from receipt of the notice from the BAC that it submitted the Lowest Calculated Bid, the Bidder shall submit the following;
 1. 2022 Income and Business Tax returns with proof of payment;
 2. Sections III and V of the Bid Documents, signed on each and every page by the bidder's authorized representative;
 3. Company profile with organizational chart and sketch of office location;
 4. Resume of key personnel who will be assigned to the project;
 5. **Manufacture's product specification certification of the polyvinyl chloride with a glass non-woven inlay and polyester fleece backing (PVC membrane with felt back);**
 6. **Manufacture's product specification certification of the expanded polystyrene (EPS) foam (EPS29);**
 7. **Brochure of the polyvinyl chloride with a glass non-woven inlay and polyester fleece backing (PVC membrane with felt back);**
 8. **Brochure of the expanded polystyrene (EPS) foam (EPS29);**
 9. **Sample of the polyvinyl chloride with a glass non-woven inlay and polyester fleece backing (PVC membrane with felt back), 60cm x 60cm;**
 10. **Sample of the expanded polystyrene (EPS) foam, EPS29, 60cm x 60 cm.**
 11. **Certification that the participating bidder has conducted ocular inspection of the subject requirements; and**
 12. **Certificate of Satisfactory Completion and Acceptance of previous PICC projects undertaken within the last five (5) years, if any.**

II. Section V- Special Conditions of the Contract have been revised to read as follows:

- GCC Clause 14- Payment
 - 5 The PICC shall deduct the following from the certified gross amounts to be paid to the **Contractor's payment:**
 - 10% as Retention money and 5% for the fifteen (15) years warranty.
 - Amount to cover the uncorrected discovered defects in the works.

III. Section VI- Technical Specifications have been changed to read as:

- **I Scope of Works and Specification:**
 - 4. Rehabilitation Works:
 - c. PVC membrane Installation
1. Site survey before application/installation is required.
 2. **Removal of blistered existing spray foam insulation.**
 3. **Treatment of corroded area by application of epoxy anti-corrosive primer.**
 4. **Installation of expanded polystyrene (EPS) foam, EPS29. The EPS foam shall be 25mm above the highest level of rib-type roof. The EPS shall be fitted to the corrugation of the existing roof (See attached plan for details. Submit sample and brochure for approval).**

EPS Foam (EPS29) Specification:

Board Size	2400mm x 1200mm	
Thickness	25mm*	
Density'. Min.	28.8kg/m ²	ASTM D6817
Compressive Resistance' @ 1% deformation min.	75 kpa	ASTM D6817
Elastic Modulos' min	7500 kpa	ASTM D6817
Flexural Strength'. Min.	345 kpa	ASTM D6817
Compressive Resistance' @ 5% deformation, min.	170 kpa	ASTM D6817
Compressive Resistance' @ 10% deformation, min.	200 kpa	ASTM D6817

*** The thickness of the EPS above the crest-top of the corrugation shall be minimum of 25mm, the total thickness**

is $\pm 50\text{mm}$ in a single profile with the filler of the corrugation depth. Use manufacturer adhesive to fix the EPS29.

IV. Section VII- Drawings have been changed to read as:

- Replacement of Page 41: **Sheet No.3 of Architectural Plan** (see attached)

The corrected copies are attached. Bidders are advised to replace their original copies with the corrected copies.

For guidance and information of all concerned.

MELPIN A. GONZAGA
Chairman

Received by:

(Signature over printed name)
Telephone/Fax No. _____
Date: _____
Name of Company: _____

10.4	<p>The key personnel must meet the required minimum years of experience set below:</p> <table border="1" data-bbox="421 277 1362 1010"> <thead> <tr> <th data-bbox="421 277 695 322">Key Personnel</th> <th data-bbox="695 277 1362 322">Relevant Experience</th> </tr> </thead> <tbody> <tr> <td data-bbox="421 322 695 584">1 – Fulltime Project-in-Charge</td> <td data-bbox="695 322 1362 584">Must have at least five (5) years’ experience as Supervisor and/or Installer in PVC membrane waterproofing works. Must have a Certificate of employment as Supervisor in the installation of the PVC waterproofing system and with Certificate of training as Installer of PVC waterproofing membrane from the manufacturer.</td> </tr> <tr> <td data-bbox="421 584 695 792">3 – PVC Membrane Installers</td> <td data-bbox="695 584 1362 792">Minimum of three (3) years’ work experience as installer of PVC membrane. Must have Certification of employment as Installer of PVC Membrane waterproofing and Certificate of training as Installer of PVC waterproofing membrane from the Manufacturer</td> </tr> <tr> <td data-bbox="421 792 695 1010">1 – Safety Officer</td> <td data-bbox="695 792 1362 1010">Minimum of three (3) years’ work experience as Safety Officer/Practitioner. Must have Certificate of employment as Safety Officer and Certificate of training in Occupational Safety and Health from DOLE or any DOLE accredited training institution.</td> </tr> </tbody> </table>	Key Personnel	Relevant Experience	1 – Fulltime Project-in-Charge	Must have at least five (5) years’ experience as Supervisor and/or Installer in PVC membrane waterproofing works. Must have a Certificate of employment as Supervisor in the installation of the PVC waterproofing system and with Certificate of training as Installer of PVC waterproofing membrane from the manufacturer.	3 – PVC Membrane Installers	Minimum of three (3) years’ work experience as installer of PVC membrane. Must have Certification of employment as Installer of PVC Membrane waterproofing and Certificate of training as Installer of PVC waterproofing membrane from the Manufacturer	1 – Safety Officer	Minimum of three (3) years’ work experience as Safety Officer/Practitioner. Must have Certificate of employment as Safety Officer and Certificate of training in Occupational Safety and Health from DOLE or any DOLE accredited training institution.	
Key Personnel	Relevant Experience									
1 – Fulltime Project-in-Charge	Must have at least five (5) years’ experience as Supervisor and/or Installer in PVC membrane waterproofing works. Must have a Certificate of employment as Supervisor in the installation of the PVC waterproofing system and with Certificate of training as Installer of PVC waterproofing membrane from the manufacturer.									
3 – PVC Membrane Installers	Minimum of three (3) years’ work experience as installer of PVC membrane. Must have Certification of employment as Installer of PVC Membrane waterproofing and Certificate of training as Installer of PVC waterproofing membrane from the Manufacturer									
1 – Safety Officer	Minimum of three (3) years’ work experience as Safety Officer/Practitioner. Must have Certificate of employment as Safety Officer and Certificate of training in Occupational Safety and Health from DOLE or any DOLE accredited training institution.									
10.5	<p>The minimum major equipment required to the project:</p> <table border="1" data-bbox="421 1122 1362 1357"> <thead> <tr> <th data-bbox="421 1122 564 1196">Item No.</th> <th data-bbox="564 1122 804 1196">Number of Units</th> <th data-bbox="804 1122 1362 1196">Description of Equipment</th> </tr> </thead> <tbody> <tr> <td data-bbox="421 1196 564 1285">1.</td> <td data-bbox="564 1196 804 1285">1 – unit</td> <td data-bbox="804 1196 1362 1285">Automatic Welding Machine for PVC Membrane</td> </tr> <tr> <td data-bbox="421 1285 564 1357">2.</td> <td data-bbox="564 1285 804 1357">3 – units</td> <td data-bbox="804 1285 1362 1357">Hand Welding Guns for PVC Membrane</td> </tr> </tbody> </table>	Item No.	Number of Units	Description of Equipment	1.	1 – unit	Automatic Welding Machine for PVC Membrane	2.	3 – units	Hand Welding Guns for PVC Membrane
Item No.	Number of Units	Description of Equipment								
1.	1 – unit	Automatic Welding Machine for PVC Membrane								
2.	3 – units	Hand Welding Guns for PVC Membrane								
12	Not applicable.									
15.1	<p>The bid security shall be in the form of a Bid Securing Declaration or any of the following forms and amounts:</p> <ol style="list-style-type: none"> <li data-bbox="421 1554 1382 1626">a. In the amount of not less than ₱339,377.80, Cash, cashier’s/manager’s check, bank draft/guarantee or irrevocable letter of credit; <li data-bbox="421 1637 1382 1671">b. Surety Bond in the amount of not less than ₱848,444.51 									
15.2	The bid security shall be valid until <i>One Hundred Twenty (120) calendar days from the date of submission and opening of bids.</i>									

16	<p>Sealing and Marking of Bids</p> <p>Each Bidder shall submit the original and one (1) copy of the first and second components of its Bid.</p>
16.1	<p>The address for submission of bids is:</p> <p style="text-align: center;">PICC-Bids and Awards Committee (BAC) Secretariat Ground floor, Delegation Building PICC Complex, 1307 Pasay City</p> <p>The deadline for submission of bids is April 29, 2024 at 10:30 a.m.</p>
17.1	<p>The place of bid</p> <p style="text-align: center;">BAC CONFERENCE ROOM Function Room B, 2nd Floor, Secretariat Building PICC Complex, 1307 Pasay City</p> <p>The date and time of bid opening is April 29, 2024 at 11:00 a.m.</p> <p>In case the Bids cannot be opened as scheduled due to justifiable reasons, the BAC shall take custody of the Bids submitted and the opening of Bids shall be at 2:00 p.m. of the next working day.</p>
19.2	Not Applicable.
20	<p>Within a non-extendible period of five (5) calendar days from receipt of the notice from the BAC that it submitted the Lowest Calculated Bid, the Bidder shall submit the following;</p> <ol style="list-style-type: none"> 1. 2022 Income and Business Tax returns with proof of payment; 2. Sections III and V of the Bid Documents, signed on each and every page by the bidder's authorized representative; 3. Company profile with organizational chart and sketch of office location; 4. Resume of key personnel who will be assigned to the project; 5. <i>Manufacturer's product specification certification of the polyvinyl chloride with a glass non-woven inlay and polyester fleece backing (PVC membrane with felt back);</i> 6. <i>Manufacturer's product specification certification of the expanded polystyrene (EPS) foam (EPS29);</i> 7. <i>Brochure of the polyvinyl chloride with a glass non-woven inlay and polyester fleece backing ((PVC membrane with felt back);</i> 8. <i>Brochure of the expanded polystyrene (EPS) foam (EPS29):</i> 9. <i>Sample of the polyvinyl chloride with a glass non-woven inlay and polyester fleece backing (PVC membrane with felt back), 60cm x 60cm;</i>

	<p><i>10. Sample of the expanded polystyrene (EPS) foam, EPS29, 60cm x 60cm.;</i></p> <p><i>11. Certification that the participating bidder has conducted ocular inspection of the subject requirements; and</i></p> <p><i>12. Certificate of Satisfactory Completion and Acceptance of previous PICC projects undertaken within the last five (5) years, if any.</i></p>
21	<p>The following documents shall be submitted, together with the Performance Bond, within ten (10) calendar days after the receipt of the Notice of Award. Such documents shall form part of the contract;</p> <ol style="list-style-type: none"> 1. Project Schedule/ Work Program and S-curve; 2. Project Safety and Health Program signed by the Safety Officer; and 3. PERT/CPM.

14	<p>Payment</p> <ol style="list-style-type: none"> 1. Full payment shall be made upon completion of the project and submission of the following documents: <ul style="list-style-type: none"> • Letter request of the Contractor for the release of the payment for work accomplished • Breakdown of work accomplished as validated and certified by PICC Representative • Photographs of work accomplished • Key plan highlighting work accomplished • As-Built Plan in soft and hard copy. The hard copy shall be in A3 bond size, three (3) copies signed by the CONTRACTOR and PICC authorized representative. The soft copy shall be saved in a USB, indicating all actual measurements, PVC membrane and fastener lay-out, details of upstand and all other necessary details needed. 2. Payment shall be subject to the following: <ul style="list-style-type: none"> • Ten percent (10%) of the contract amount as retention money. The total “retention money” shall be due for release upon final acceptance of the works, and • Five percent (5%) of the contract amount as guarantee for the fifteen year (15) warranty period. Said amount shall be released after accomplishing the condition under item 3 of the warranty conditions 3. The five percent (5%) of the contract amount withheld for the warranty shall be released equally, twice a year, for fifteen (15) years, after submission of a letter request, inspection report, the warranty security and notarized warranty certificate from the contractor. The inspection shall be at least every six (6) months starting from the date of the final turn-over and acceptance of the project. 4. The PICC representative shall check the contractor’s request for payment and certify the amount to be paid to the contractor as progress payments. Materials and equipment delivered on the site but not completely put in place shall not be included for payment. 5. The PICC shall deduct the following from the certified gross amounts to be paid to the <i>Contractor’s payment</i>: <ul style="list-style-type: none"> • 10% as Retention money and 5% for the fifteen (15) years warranty. • Amount to cover the uncorrected discovered defects in the works.
----	--

SUPPLY OF LABOR AND MATERIALS FOR REHABILITATION OF THE ROOF OF MEETING ROOM 1

I. SCOPE OF WORKS and SPECIFICATIONS:

The works shall be supply of all materials, labor, tools, equipment and other incidental necessary for the rehabilitation of the roof of Meeting Room 1 and masonry works.

The following features of the work shall be performed, but not limited to the following:

1. Mobilization

Manpower, tools, equipment and temporary warehouse.

2. Health and Safety requirements

- a. Installation of 2 - safety signage per area, same as the PICC standard signage, 22" x 32". See attached drawing.
- b. Provide portable fire extinguishers, at least two (2) units per location.
- c. Personal Protective Equipment (PPE). The Contractor shall comply with the requirements under DPWH and DOH (protocol against COVID-19)
- d. All workers shall wear their company uniform together with the required PPEs. (See item 10 in General Conditions)

3. Demobilization

Manpower, tools, equipment, temporary warehouse, including hauling-out of construction debris.

4. Rehabilitation works:

- a. The Bidder shall inspect and measure the actual area to be waterproofed and verify its condition.
- b. Inspection of the existing utilities: Examine all the existing utilities and its status to receive the PVC membrane. The existing utilities are the air-conditioning systems and other electrical utilities. The Bidder shall inspect carefully the existing conditions that may affect the installation and costing of the project.
- c. PVC membrane installation:

Roof of Meeting Room 1:

1. Site survey before application/installation is required.
2. *Removal of blistered of existing spray foam insulation.*
3. *Treatment of corroded area by application of epoxy anti-corrosive primer.*
4. *Installation of expanded polystyrene (EPS) foam, EPS29. The EPS foam shall be 25mm above the highest level of rib-type roof. The EPS shall be fitted to the corrugation of the existing roof. (See attached plan for details. Submit sample and brochure for approval).*

EPS Foam (EPS29) Specification:

Board Size	2400mm x 1200mm	
Thickness	25mm*	
Density'. Min.	28.8kg/m ²	ASTM D6817
Compressive Resistance' @ 1% deformation min.	75 kpa	ASTM D6817
Elastic Modulos' min	7500 kpa	ASTM D6817
Flexural Strength'. Min.	345 kpa	ASTM D6817
Compressive Resistance' @ 5% deformation, min.	170 kpa	ASTM D6817
Compressive Resistance' @ 10% deformation, min.	200 kpa	ASTM D6817

**The thickness of EPS above the crest-top of the corrugation shall be minimum of 25mm, the total thickness is ±50mm is a single profile with the filler of the corrugation depth. Use manufacturer adhesive to fix the EPS29.*

5. Installation of non-asbestos 8mm fiber cement (ficem) board. The ficem board shall be screw to the existing purlins of the roof, spacing at 60cm. Submit sample of ficem board and screw for approval.
6. Installation of fully adhered polyvinyl chloride with a glass non-woven inlay and polyester fleece backing (PVC membrane with felt), install with approved manufacturer's adhesive. Submit 60cm x60cm sample for PVC membrane with felt and manufacturer's certification of the product specifications.

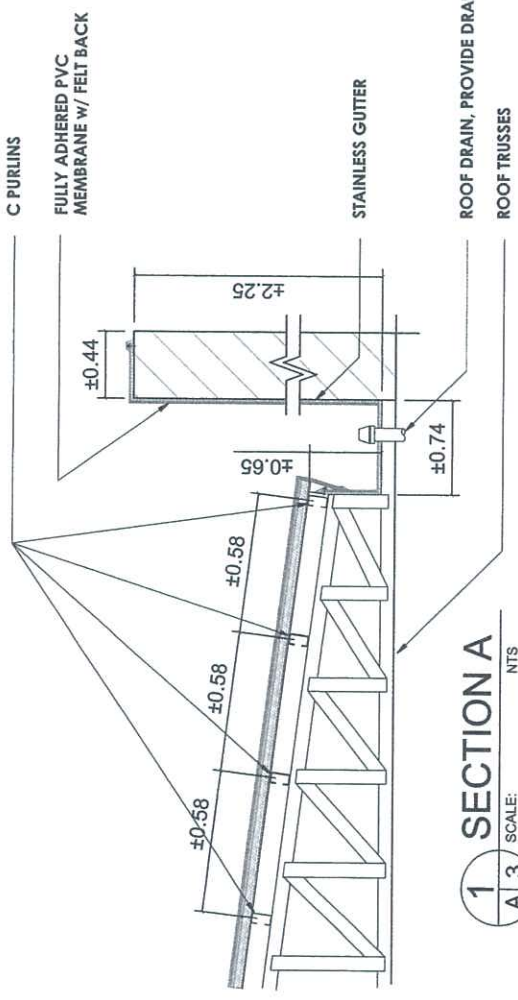

1 SECTION A
SCALE: $\frac{A}{3}$ NTS

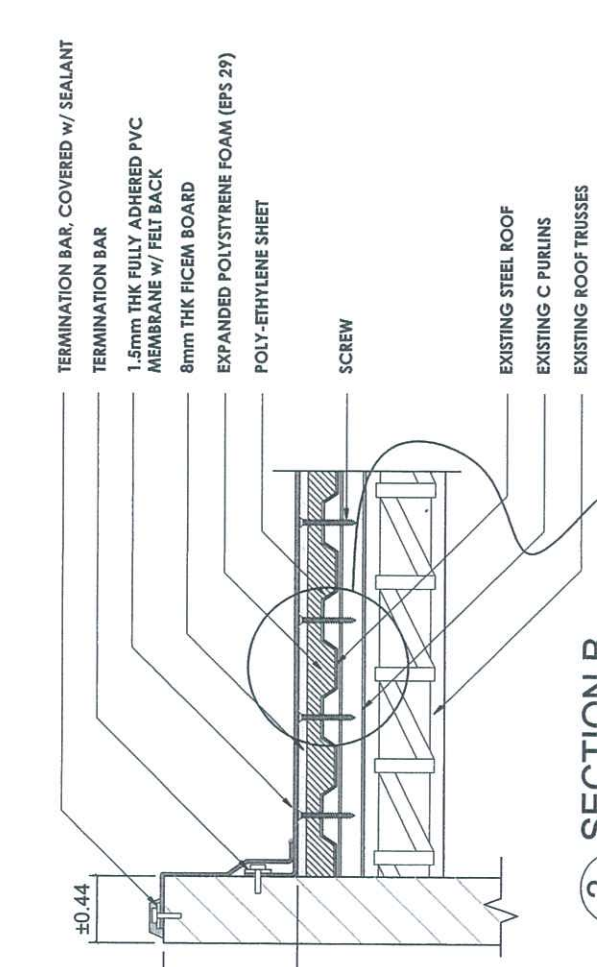

2 SECTION B
SCALE: $\frac{A}{3}$ NTS

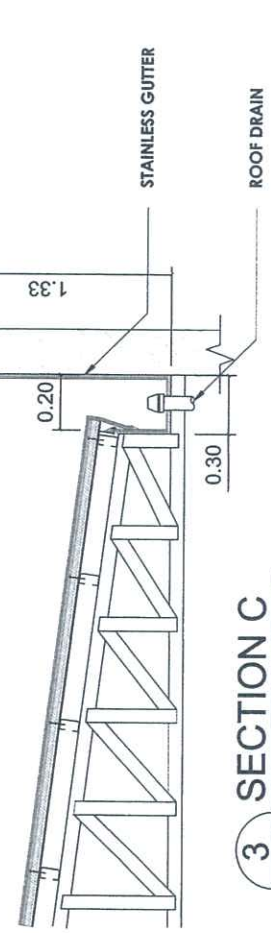

3 SECTION C
SCALE: $\frac{A}{3}$ NTS

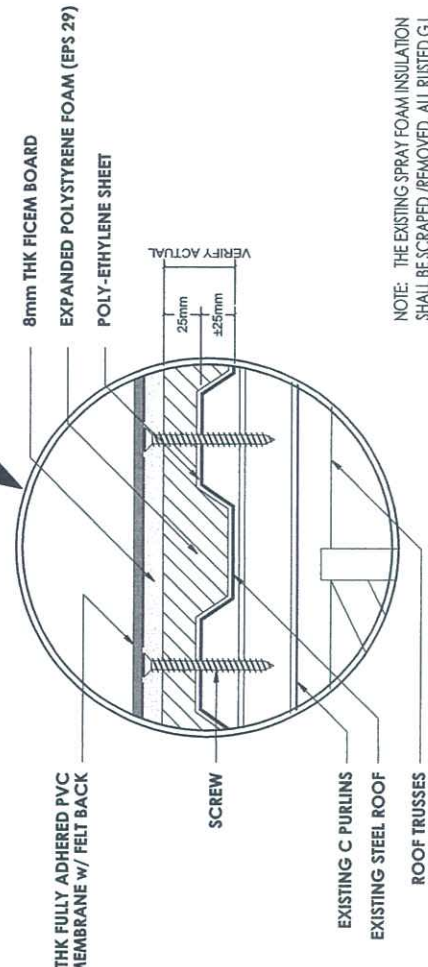

4 BLOWUP DETAIL
SCALE: $\frac{A}{3}$ NTS

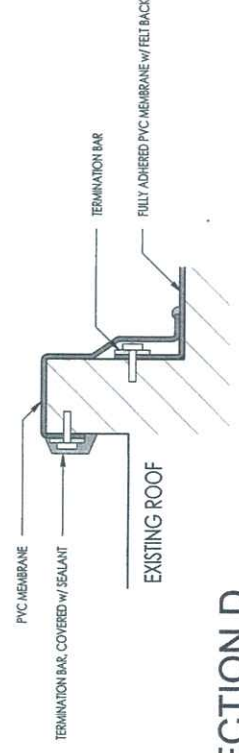

5 SECTION D
SCALE: $\frac{A}{3}$ NTS

NOTE: THE EXISTING SPRAY FOAM INSULATION SHALL BE SCRAPPED / REMOVED. ALL RUSTED G.I. ROOFING SHALL BE TREATED WITH EPOXY ANTI-CORROSIIVE PRIMER BEFORE INSTALLING THE POLY-ETHYLENE SHEET.

REVISED DETAIL
TO SUPERSEDE THE SHEET NO. 3

 Pittsburgh International Convention Center	TITLE SUPPLY OF LABOR & MATERIALS FOR THE REHABILITATION OF THE ROOF OF MEETING ROOM 1		DATE 07.27.2023	REVISION 4.17.2024	SHEET NO. 3
	LOCATION DELEGATION BUILDING		AUTOCAD BY LOUIE JAY E. GADON AUTOCAD OPERATOR	RECOMMENDING APPROVAL  AR. REYNALDO B. MENDOZA JR. BLDG. SERVICES OFFICER	APPROVED BY  ENGR. EDISONT AURELIO ASSISTANT DIRECTOR, BSD-1SD